

THE INFORMATION CONTAINED IN THIS DRAWING IS THE SOLE PROPERTY OF PROMATS, INC. AND ANY REPRODUCTION IN PART OR WHOLE WITHOUT THE WRITTEN PERMISSION OF PROMATS, ...

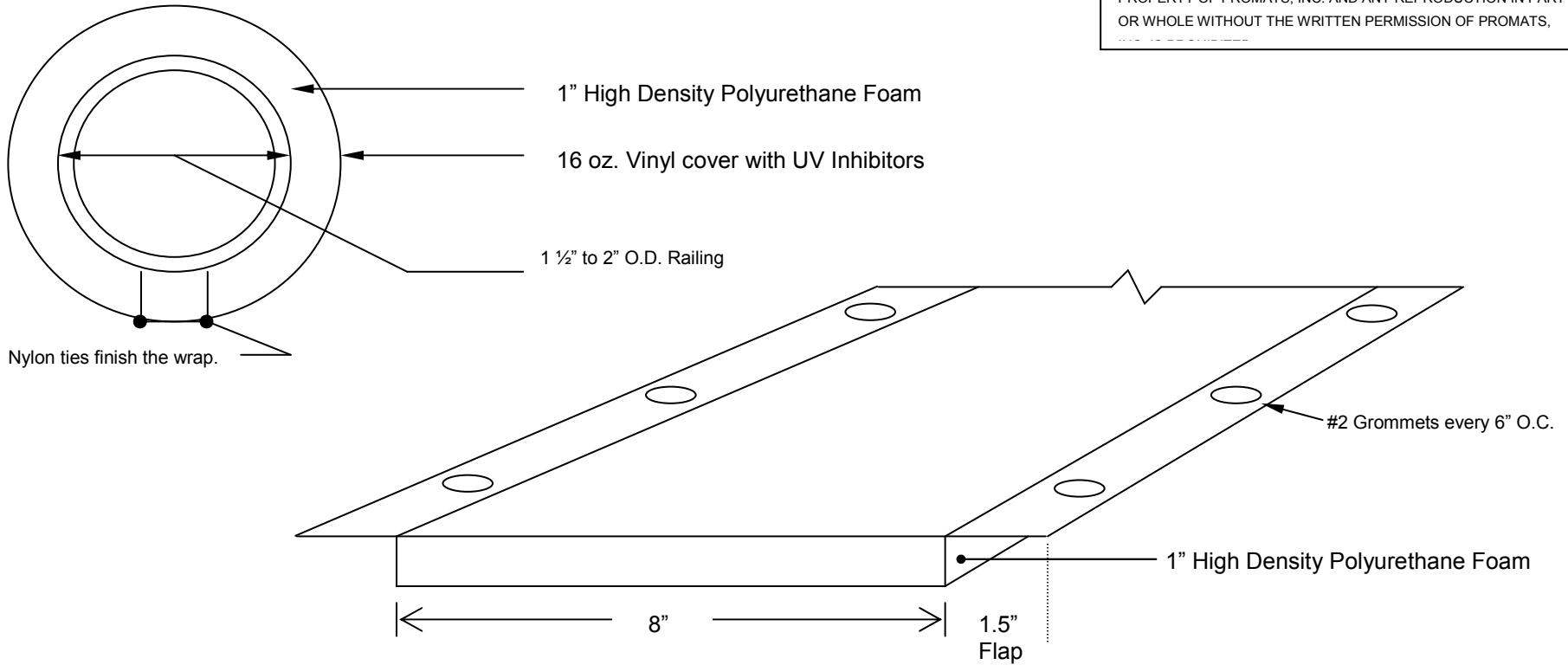

**Field Wall Padding Specifications:  
Guard Rail Padding (GRP10)**

Vinyl Covering: 16 oz. per sq. yard laminated vinyl, unbalanced coating. Fabric: 1000 Denier Polyester Basic Fabric, Tear Strength Test: Warp 85 lbs., Fill 83 lbs., Tensile Strength: Warp 221 lbs., Fill 216 lbs., Weft Insertion: 9 x 9, Superior UV inhibitors, Cold Crack: Minus 20 degrees Fahrenheit, Class A flame retardant. Colors per manufacturer's standard selection, as selected by Architect. Vinyl cover is stitched using 6 lb. Bonded polyester Black thread.

Filler Foam for guardrail and handrail pads: 1" thick Polyurethane Foam, Density: 1.7 - 1.9 lb./cu ft., Indention Load Deflection: 81 - 99 lbs., Tensile Strength: 20 psi min., Elongation: 100% min., Tear Strength: 1.50 lbs./LIN. min.

Attachment: 2 - 1 1/2" Vinyl flaps with #2 grommets every 6" O.C. Attached to rail using 14" nylon ties, 50 lb. Break.

March 22, 2007
Guard Rail Padding (GRP10)
NOT TO SCALE



Post Office Box 508  
Fort Collins, CO 80522-0508  
800-678-6287  
FAX 970-482-7740

Drawn By:
Drawing #:

Project Name: