

THE INFORMATION CONTAINED IN THIS DRAWING IS THE SOLE PROPERTY OF PROMATS, INC. AND ANY REPRODUCTION IN PART OR WHOLE WITHOUT THE WRITTEN PERMISSION OF PROMATS, IS PROHIBITED.

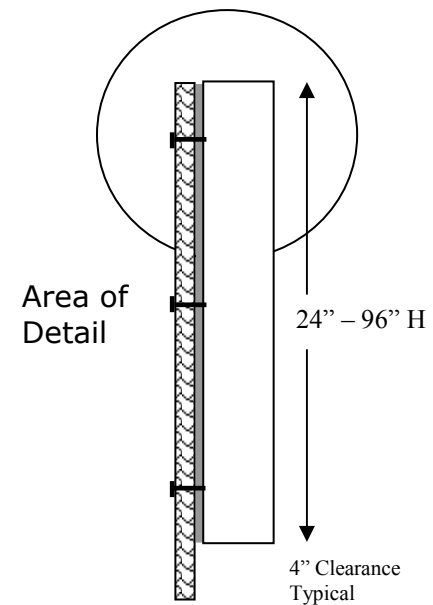

**Field Wall Padding Specifications:  
Exterior Use (FWPCL)**

**Backing:** 23/32 inch APA BC exterior grade plywood, primed on edges and backside. Exposed plywood surface is painted to match vinyl color.

**Vinyl Covering:** 16 oz. per sq. yard laminated vinyl, unbalanced coating. Fabric: 1000 Denier Polyester Basic Fabric, Tear Strength Test: Warp 85 lbs., Fill 83 lbs., Tensile Strength: Warp 221 lbs., Fill 216 lbs., Weft Insertion: 9 x 9, Superior UV inhibitors, Cold Crack: Minus 20 degrees Fahrenheit, Class A flame retardant. Colors per manufacturer's standard selection, as selected by Architect. Vinyl cover is wrapped around the backside of the plywood and stapled every 3" with galvanized steel staples. Each pad has 3 weep holes to evacuate moisture.

**Filler Foam:** 3" thick High Impact Foam. Filler foam is glued to plywood backing.

**Adhesive:** Synthetic Resin Rubber Base, High Flexibility Factor, Water Resistant, Heat & Cold Resistant, High Bonding Factor.

**Attachment:** A minimum of six 1/4" x 1 1/2" bolts screwed into 1/4" threaded washer inserts with 1/8" x 3" round backing plates.

March 27, 2007

Exterior Wall Pad for Chain  
Link Fence (FWPCL)

NOT TO SCALE



Post Office Box 508  
Fort Collins, CO 80522-0508  
800-678-6287  
FAX 970-482-7740

Drawn By:

Drawing #:

Project Name: