

THE INFORMATION CONTAINED IN THIS DRAWING IS THE SOLE PROPERTY OF PROMATS, INC. AND ANY REPRODUCTION IN PART OR WHOLE WITHOUT THE WRITTEN PERMISSION OF PROMATS, INC. IS PROHIBITED.

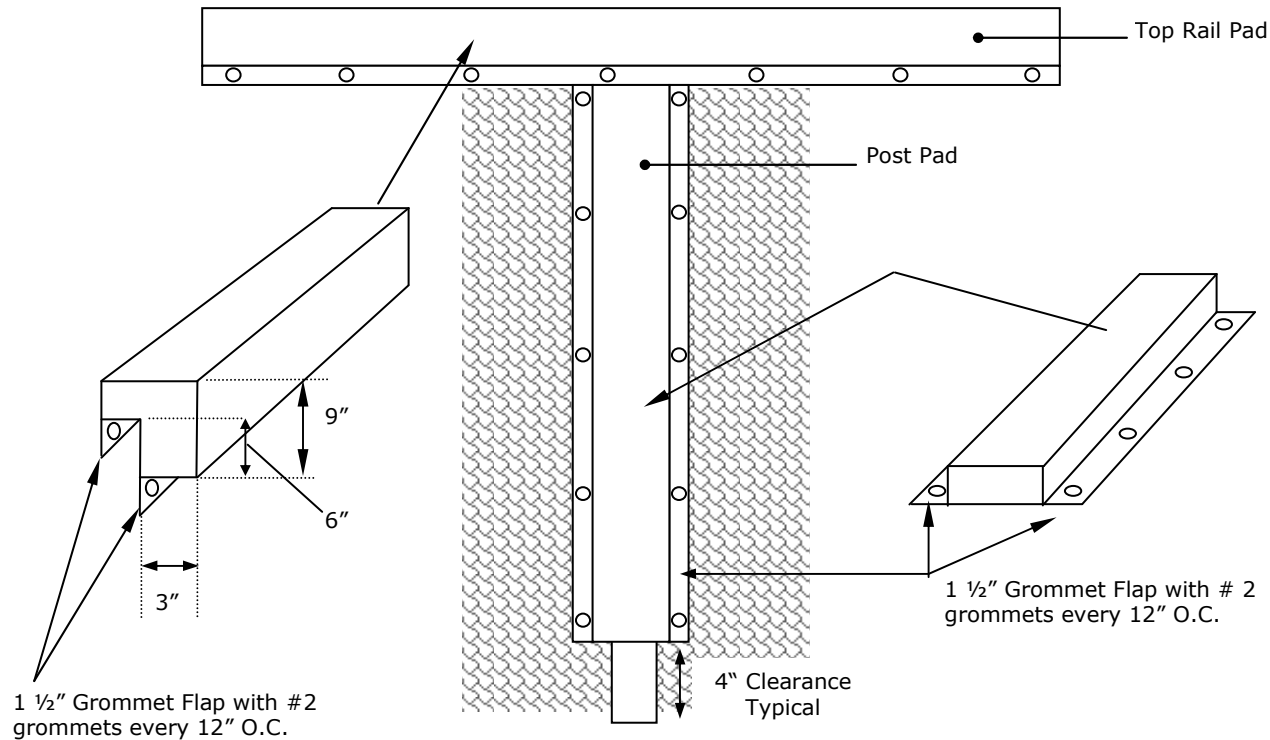

**Padding Specifications:
Top Rail (CLTR) & Post Padding (CLP)**

Application: Chain Link Fence Posts, Railings, Masonry and Wooden Walls.
Vinyl Covering: 16 oz. per sq. yard laminated vinyl, unbalanced coating. Fabric: 1000 Denier Polyester Basic Fabric, Tear Strength Test: Warp 85 lbs., Fill 83 lbs., Tensile Strength: Warp 221 lbs., Fill 216 lbs., Weft Insertion: 9 x 9, Superior UV inhibitors, Cold Crack: Minus 20 degrees Fahrenheit, Class A flame retardant. Colors per manufacturer's standard selection, as selected by Architect. Vinyl cover is stitched using 6 lb. Bonded polyester thread, color: Black.
Filler Foam for fence post and top rail pads: 3" thick High Impact Foam.
Attachment: 1 1/2" Vinyl flap with #2 grommets every 12" O.C. Attached to fence using 14" nylon ties, 50 lb. Break.

March 22, 2007
Top Rail (CLTR) & Post Padding (CLP)
NOT TO SCALE



Post Office Box 508
 Fort Collins, CO 80522-0508
 800-678-6287
 FAX 970-482-7740

Drawn By: _____
 Drawing #: _____

Project Name: _____